

MICROBIAL MONITORING CONTINUOUS & INTERVENTION-FREE

THE BIOTRAK® REAL-TIME VIABLE PARTICLE COUNTER



UNDERSTANDING, ACCELERATED

INNOVATION FOR A CHANGING INDUSTRY

Aseptic manufacturing is changing. Ushered in by technologies such as isolators and single-use systems, automated processes with limited human interventions are rapidly becoming reality. Regulators and manufacturers alike recognize the improved safety and efficiency of highly-automated, continuous manufacturing. This new paradigm demands in-depth process understanding, tight in-process control testing, and fewer interruptions with minimal operator intervention. After decades of reliable service, traditional microbial monitoring techniques (i.e. growth-based detection methods) have not adequately evolved to this changing manufacturing environment.

The BioTrak® Real-Time Viable Particle Counter provides real-time viable and non-viable particle monitoring of critical environments, including the aseptic core, without the need for operator intervention. It also simultaneously supports sample collection for identification. The BioTrak Real-Time Viable Particle Counter complements manufacturing innovations to maximize process understanding and improve manufacturing efficiency.

As aseptic manufacturing evolves, so should microbial monitoring. The BioTrak Real-Time Viable Particle Counter enables manufacturers to maximize safety and efficiency. Don't compromise your manufacturing process for traditional microbial monitoring; see how the BioTrak Real-Time Viable Particle Counter can benefit your company.



REDUCE RISK & IMPROVE EFFICIENCY

Eliminate aseptic interventions for microbial monitoring. BioTrak® Particle Counter allows continuous, fully-automated microbial monitoring.

ONE PRODUCT THREE INSTRUMENTS

+ VIABLE PARTICLES

+ NON-VIABLE PARTICLES

+ MICROBIAL COLLECTION

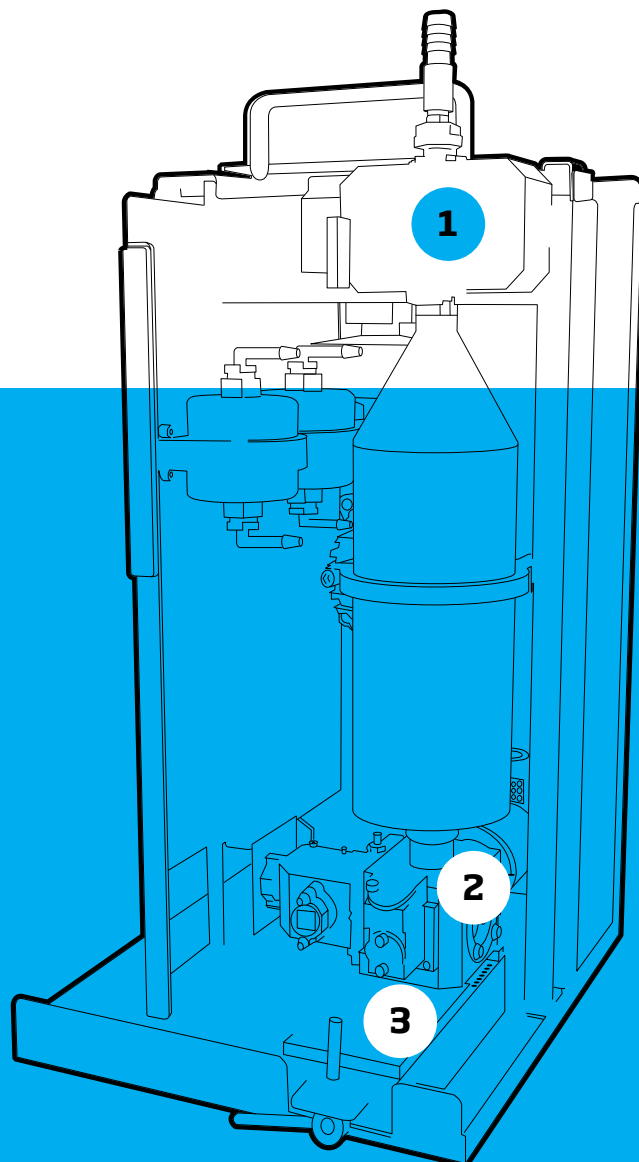

With over 40 years of particle counting experience, and 20 years of viable particle detection in the defense-and-threat detection field, TSI delivers confidence with the BioTrak Real-Time Viable Particle Counter. Dual-channel, Laser Induced Fluorescence (LIF) technology provides the best viable measurements of any real-time Rapid Microbial Method (RMM) available on the market today. And, with TSI you will be working with a trusted, knowledgeable partner in regulated life-science contamination control markets.

1. Particle Counter

Built-in 1 CFM (28.3 LPM), ISO 21501-4 compliant particle counter measures Total Particle Count (T-CNT). This component is used to classify cleanrooms to ISO 14644-1 and EU GMP standards.

2. Viability Detector

Real-time single-particle viability detector utilizes TSI's dual-channel laser induced fluorescence technology for the best discrimination available.

3. Collection Filter

Industry standard 37-mm integrated collection filter captures and maintains viability of optically analyzed particles for subsequent laboratory analysis.

IMPROVE EFFICIENCY

APPLICATIONS

Continuous Process Monitoring

The BioTrak Real-Time Viable Particle Counter is the ideal solution for continuous microbial monitoring in the aseptic manufacturing core. Real-time, interruption-free monitoring unlocks process efficiencies and improves quality control. Seamless integration with TSI's Facility Monitoring System enables complete EM automation.

Routine Environmental Monitoring

In Grades C/D (ISO 8), the BioTrak Particle Counter is a single instrument for cleanroom certification and episodic monitoring—providing viable and total particle data, as well as sample collection for identification.

Non-Compliance Based Applications

These applications, such as root-cause investigation, room release, and gowning training/verification, offer immediate benefit for any facility. The BioTrak Particle Counter has features and accessories designed for easy operation and data analysis.

VALIDATION

- + TSI has a dedicated team of professionals with knowledge and experience to help you confidently implement the BioTrak Particle Counter in a compliant manner.
- + TSI has submitted a Type V Drug Master File with the FDA. It includes rigorous performance qualification studies. A summary is available upon request or via the website.
- + In addition, see guidances related to Alternative Microbiological Methods in USP <1223>, EP 5.1.6, and PDA TR33.

Type-V Drug Master File (DMF)

From evaluation to validation, TSI is committed to helping customers implement the BioTrak Particle Counter for compliance-based applications. The related Drug Master File describes a rigorous validation performed by TSI and third-party professionals using the latest in aerosol techniques following relevant guidances.

& REDUCE RISK



BENEFITS



Reduce Operator Interventions

By sampling air from within the aseptic core while physically outside that space, there is no need for operators to intervene for microbial monitoring.

Reduce Line Stoppages

Line stoppages increase risk, require costly mitigation, and can even lead to wasted product. By eliminating interventions, the BioTrak Real-Time Viable Particle Counter allows continuous operation during fill and finish.

Improve Process Understanding

Continuous monitoring reveals where and when microbial excursions occur. Time-resolved data demonstrates continuous control during normal operation and saves time and resources following excursions.

Rapidly Demonstrate Control

The BioTrak Particle Counter can demonstrate environmental control in real-time. With real-time evidence, there is no need for excessive cleaning cycles or air exchange to ensure cleanliness.

Seamlessly Integrated Microbial Monitoring

Data integrity is critical. The BioTrak Particle Counter seamlessly interfaces with TSI's FMS Facility Monitoring Software, a fully compliant continuous monitoring software package that trends data and records alarms.

BETTER DISCRIMINATION

DUAL-CHANNEL LASER INDUCED FLUORESCENCE (LIF)

Microorganisms contain fluorescent molecules that produce unique optical signatures. By measuring the size and fluorescent properties of individual particles, TSI's BioTrak Real-Time Viable Particle Counter effectively distinguishes viable particles from non-viable particles.

At the heart of the BioTrak Viable Particle Counter is our Laser Induced Fluorescence (LIF) technology. Simply stated, when microbial particles are exposed to ultra-violet laser light, they absorb and re-emit light at higher wavelengths; a process called fluorescence. Fluorescent cell metabolites associated with viability, such as nucleotides, flavins, lipids, and amino acids, are the primary markers targeted by the LIF technique.

Unlike products with just one channel of fluorescence detection, TSI's BioTrak Viable Particle Counter has two channels for better discrimination. In the example shown, it is impossible to differentiate the pollen particles from the microorganisms using a single fluorescence channel. But, when a second channel of detection is added, the differentiation becomes clear. By collecting and processing more optical data than other instruments, TSI has produced the most discriminating measurement on the market today.

FIGURE 1: Single Channel

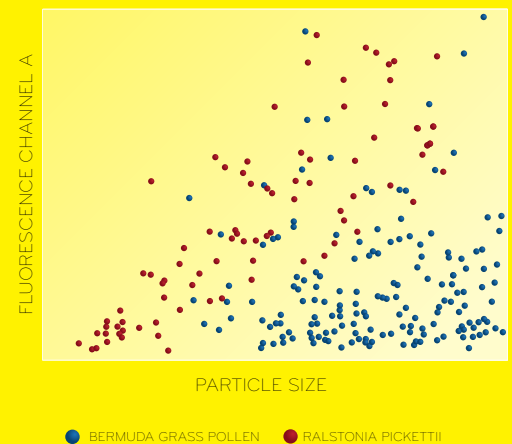

A single channel of fluorescence makes it very difficult to discriminate viable from non-viable particles.

FIGURE 2: Dual Channel

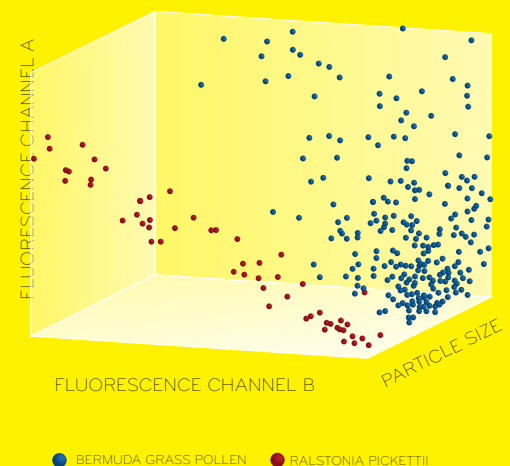

TSI's two channels of fluorescence detection provides the better measurement by clearly discriminating the viable particles.

BETTER RESULTS

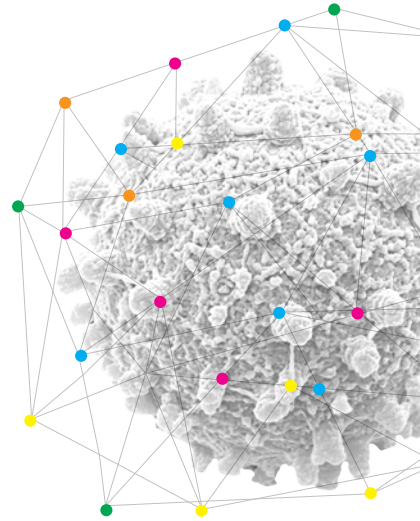

SPECIFICITY



A viable particle count in the absence of a microorganism is considered a false-positive. In critical environments, such as the aseptic core, false-positives can adversely impact processes. With dual-channel LIF and sophisticated discrimination algorithms, the BioTrak Viable Particle Counter reliably delivers essentially zero viable particle counts in rigorously hygienic spaces such as Grade A / ISO 5. The graph shows actual data from real-world manufacturing spaces. The BioTrak Particle Counter shows little or no signal in extremely clean environments for as long as aseptic conditions are maintained.

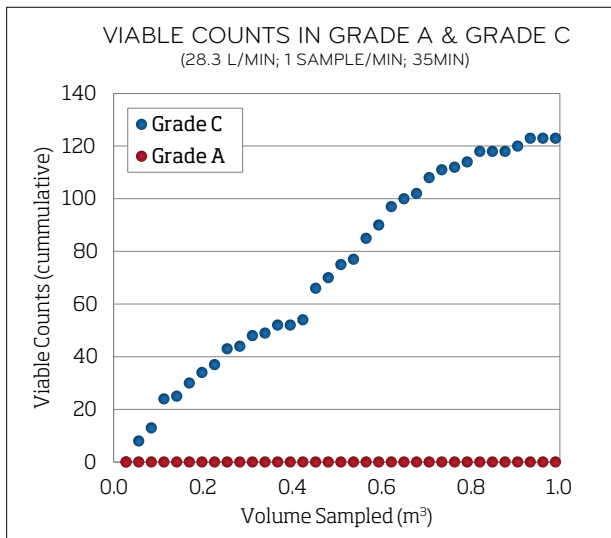

SENSITIVITY

Two sensitivity settings allow for appropriate response in the area you wish to monitor.

The most sensitive setting is for critical process monitoring in Grade A/B and ISO 5/7 areas where there are very clean particle backgrounds and no viable particle can be missed.

A less sensitive setting is ideal for Grade C/D and ISO 8 areas where the particle backgrounds are more likely to contain interferences. This setting will minimize false positives.

TSI – A LEADER IN PARTICLE COUNTING

For over 40 years, TSI has been a recognized leader in accurate particle measurements. In fact, TSI is considered the leader in aerosol and particle instrumentation for many applications, including: filter testing, atmospheric and climate studies, ambient air monitoring, nanoparticle measurements, dust monitoring, respirator fit testing, engine emissions, aerosol research, clean room certification, and bio detection.

AeroTrak® Particle Counters - Where Research Meets Reality

The AeroTrak® line of particle counters, including handhelds, portables, and remotes, are designed to meet the rigid requirements for life science cleanroom applications. AeroTrak Particle Counters comply with the stringent requirements set forth in ISO 21501-4. These particle counters are calibrated to NIST traceable PSLs using TSI's world-class classifier and condensation particle counters, the recognized standard for particle measurements. Backed with TSI's long-standing reputation for high quality and accuracy, AeroTrak Particle Counters provide the best measurement and data to help keep your processes in control.

*Patents: 5,701,012; 5,895,922; 6,831,279



UNDERSTANDING, ACCELERATED

TSI Incorporated - Visit our website www.tsi.com for more information.

USA	Tel: +1 800 874 2811	India	Tel: +91 80 67877200
UK	Tel: +44 149 4 459200	China	Tel: +86 10 8219 7688
France	Tel: +33 1 41 19 21 99	Singapore	Tel: +65 6595 6388
Germany	Tel: +49 241 523030		